

HOUSING SIZE	SHAFT DIAMETER $d$ (mm)	PLUMMER BLOCK HOUSING	PLUMMER BLOCK HOUSING DIMENSIONS ( mm )										
			$D$ ( H8 )	$B$	$b$	$G$	$F$ ( H13 )	$A$ ( h13 )	$L$	$H$	$E$	$d_1$ ( H12 )	$d_2$ ( H13 )
SN 206	30	SN 206	62	185	52	22	30.0	50	77	90	150	36.5	48
SN 207	35	SN 207	72	185	52	22	33.0	50	82	95	150	46.5	58
SN 208	40	SN 208	80	205	60	25	33.0	60	85	112	170	51.5	67
SN 209	45	SN 209	85	205	60	25	31.0	60	85	112	170	56.5	72
SN 210	50	SN 210	90	205	60	25	33.0	60	90	115	170	62.0	77
SN 211	55	SN 211	100	255	70	28	33.0	70	95	130	210	67.0	82
SN 212	60	SN 212	110	255	70	30	38.0	70	105	135	210	72.0	89
SN 213	65	SN 213	120	275	80	30	43.0	80	110	150	230	77.0	94
SN 215	75	SN 215	130	280	80	30	41.0	80	115	155	230	87.0	104
SN 216	80	SN 216	140	315	90	32	43.0	95	120	175	260	92.0	111
SN 217	85	SN 217	150	320	90	32	46.0	95	125	185	260	97.0	120
SN 218	90	SN 218	160	345	100	35	62.4	100	145	195	290	102.0	125
SN 220	100	SN 220	180	380	110	40	70.3	112	160	215	320	118.0	140
SN 222	110	SN 222	200	410	120	45	80.0	125	175	239	350	128.0	154
SN 224	120	SN 224	215	410	120	45	86.0	140	185	270	350	138.0	164
SN 226	130	SN 226	230	445	130	50	90.0	150	190	290	380	148.0	178
SN 228	140	SN 228	250	500	150	50	98.0	150	205	305	420	158.0	188
SN 230	150	SN 230	270	530	160	60	106.0	160	220	325	450	168.0	198
SN 232	160	SN 232	290	550	160	60	114.0	170	235	340	470	178.0	208

Remark: All SN housings available with Felt-seals (FS).

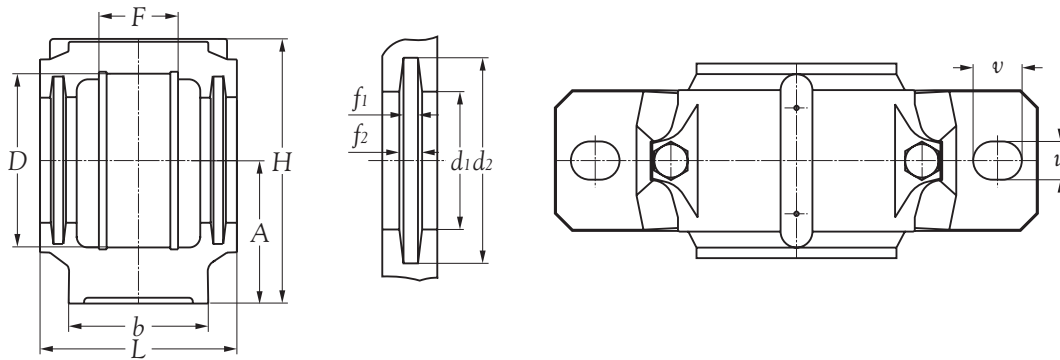

PLUMMER BLOCK HOUSING DIMENSIONS ( mm )							APPROPRIATE APARTMENT					
f <sub>1</sub>	f <sub>2</sub>	u	v	s	t	WEIGHT Kg	BEARING NUMBER		LOCATING RING		FELT SEAL	END COVER
									NUMBER	QTY		
4	5.4	15	20	M 12	M 8	2.3	1206		SR 62X7	2	FS 6X6X135	508 NA
							2206	22206	SR 62X10	1		
4	5.4	15	20	M 12	M 10	2.3	1207		SR 72X8	2	FS 6X6X165	510 NA
							2207	22207	SR 72X10	1		
5	6.9	15	20	M 12	M 10	3.2	1208		SR 80X7.5	2	FS 6X9X190	511 NA-510 UA
							2208	22208	SR 80X10	1		
5	6.9	15	20	M 12	M 10	3.2	1209		SR 85X6	2	FS 6X9X205	512 NA-511 UA
							2209	22209	SR 85X8	1		
5	6.8	15	20	M 12	M 10	3.3	1210		SR 90X6.5	2	FS 6X9X220	513 NA-512 UA
							2210	22210	SR 90X10	1		
5	6.8	18	23	M 16	M 12	4.4	1211		SR 100X6	2	FS 6X9X235	515 NA-513 UA
							2211	22211	SR 100X8	1		
6	8.1	18	23	M 16	M 12	5.0	1212		SR 110X8	2	FS 8X10X255	516 NA
							2212	22212	SR 110X10	1		
6	8.1	18	23	M 16	M 12	5.9	1213		SR 120X10	2	FS 8X10X270	517 NA-515 UA
							2213	22213	SR 120X12	1		
6	8.1	18	23	M 16	M 12	7.0	1215		SR 130X8	2	FS 8X10X300	519 NA-517 UA
							2215	22215	SR 130X10	1		
7	9.3	22	27	M 20	M 16	8.9	1216		SR 140X8.5	2	FS 9X10X320	520 NA-518 UA
							2216	22216	SR 140X10	1		
8	10.8	22	27	M 20	M 16	9.1	1217		SR 150X9	2	FS 10X13X340	217 NA
							2217	22217	SR 150X10	1		
8	10.8	22	27	M 20	M 16	13.1	1218		SR 160X16.2	2	FS 10X13X360	522 NA
							2218	22218	SR 160X11.2	2		
							23218		SR 160X10	1		
8	10.7	26	32	M 24	M 20	17.5	2220		SR 180X12.1	2	FS 10X13X410	526 NA-519 UA
							22320		SR 180X10	1		
9	12.2	26	32	M 24	M 20	21.6	2222		SR 200X13.5	2	FS 12X14X445	528 NA-522 UA
							23222		SR 200X10	1		
9	12.2	26	32	M 24	M 20	24.2	22224		SR 215X14	2	FS 12X14X475	530 NA-524 UA
							23224		SR 215X10	1		
10	13.7	28	36	M 24	M 24	30.2	22226		SR 230X13	2	FS 12X17X515	226 NA
							23226		SR 230X10	1		
10	13.7	33	42	M 30	M 24	41.0	22228		SR 250X15	2	FS 12X17X545	228 NA
							23228		SR 250X10	1		
10	13.7	33	42	M 30	M 24	46.0	22230		SR 270X16.5	2	FS 12X17X580	230 NA
							23230		SR 270X10	1		
10	13.7	33	42	M 30	M 24	57.5	22232		SR 290X17	2	FS 12X17X610	232 NA
							23232		SR 290X10	1		

Remark: All SN housings available with Felt-seals (FS).